



UNITED STATES PATENT AND TRADEMARK OFFICE

UNITED STATES DEPARTMENT OF COMMERCE
United States Patent and Trademark Office
Address: COMMISSIONER FOR PATENTS
P.O. Box 1450
Alexandria, Virginia 22313-1450
www.uspto.gov

APPLICATION NO.	FILING DATE	FIRST NAMED INVENTOR	ATTORNEY DOCKET NO.	CONFIRMATION NO.
09/589,881	06/09/2000	Jeongmin Moon	3430-0105P	1734

7590 06/14/2006
Birch Stewart Kolasch & Birch LLP
P O Box 747
Falls Church, VA 22040-0747

EXAMINER

NGUYEN, HOAN C

ART UNIT PAPER NUMBER

2871

DATE MAILED: 06/14/2006

Please find below and/or attached an Office communication concerning this application or proceeding.

09/589-881



**UNITED STATES DEPARTMENT OF COMMERCE
U.S. Patent and Trademark Office**

W

Address: COMMISSIONER FOR PATENTS
P.O. Box 1450
Alexandria, Virginia 22313-1450

APPLICATION NO./ CONTROL NO.	FILING DATE	FIRST NAMED INVENTOR / PATENT IN REEXAMINATION	ATTORNEY DOCKET NO.
---------------------------------	-------------	---	---------------------

EXAMINER

ART UNIT	PAPER
----------	-------

20060607

DATE MAILED:

Please find below and/or attached an Office communication concerning this application or proceeding.

Commissioner for Patents

Approved.
Janice A. Falcone
JANICE A. FALCONE
DIRECTOR
TECHNOLOGY CENTER 2800

Art Unit: 2871

1. The reply brief filed October 11, 2005 has been entered and considered. The application has been forwarded to the Board of Patent Appeals and Interferences for decision on the appeal.

2. Responsive to Reply Brief on October 11, 2005, a supplemental Examiner's Answer is set forth below:

On Shinji et al. (US6259854):

Applicants still believe that SHINJI DOES NOT TEACH THAT WHEN THE ANGLE BETWEEN THE LOWER SURFACE AND A SURFACE CONNECTING THE PLANAR SURFACE OF THE CONVEX PORTION IS ABOUT 90° THE LIGHT REFLECTED ALONG AN ORTHOGONAL DIRECTION TO THE LIQUID CRYSTAL DISPLAY DEVICE IS UNIFORM.

Examiner still holds his position on the following reasons:

- First, applicants fail to demonstrate with Snell Law on Figure 4-5 that how light strikes a side 515/517 of one of the convex portions 511 and becomes directed downwardly substantially perpendicular to the reflector 507 (light can strike any direction at a side of one of the convex portions and becomes directed downwardly in any direction, not perpendicular).
- Second, Shinji discloses (TABLE 1, Figure 4) when angle $\delta < 3^\circ$ and setting $W=20\mu\text{m}$, $H/W=0.6$, uniformity ratio of illuminance equals to 72% (it is bad comparing to 100% of perfect uniformity ratio). Claims 1, 11 and 21 recite "light reflected along orthogonal direction to the liquid crystal is UNIFORM". Applicants do not mention any quality of UNIFORM or do not claim how good UNIFORM

Art Unit: 2871

must required (is it about 72% or 100% uniformity?). In reply, applicants start to discuss about the quality (bad or good) of uniformity, which never mentioned in their application or claims. However, as Figure 5 shown in their application, applicants need further disclose the dimensions of the angle 523, the width d2 and the height 525 to have a good (or not bad) uniformity (about 100% uniformity ratio).

- Examiner believes that the proof in Examiner Answer is correct; for example:

If $\delta=0^\circ$, $\Theta_i = \Theta$, therefore, with $n_{\text{PMMA}}=1.49$ of the light guider and $n_{\text{air}}=1.00$ as

Figure 4 shown, Snell Law:

$$n_{\text{air}} \sin\Theta_r = n_{\text{PMMA}} \sin\Theta_i \quad (1)$$

$$\Theta_i = \Theta \quad (2)$$

$$\Theta_r = 90^\circ \quad (3)$$

replacing (2) and (3) into (1):

$$(1.00) \sin(90^\circ) = (1.49) \sin(\Theta)$$

$$1/1.49 = \sin\Theta;$$

Therefore, $\Theta_i = \Theta = 42.15^\circ < \Theta_c = 47.8^\circ$. It is not a total internal reflection; therefore, light becomes deflect outwardly or downwardly (see attachments 1 and 2).

Furthermore, the guide light in Shinji et al. as Figure 4 shown and the guide light in the instant invention as Figure 5 shown are similar geometry or shape (see attachment 3); therefore, any optical phenomena in Figure 5 of the instant invention must be inherent in Figure 4 of Shinji; thereby the feature of directing light to a reflector outwardly in an orthogonal direction must be INHERENT in Shinji. **Examiner also**

Art Unit: 2871

requires a proof from applicant for the feature of directing light to a reflector outwardly in an orthogonal direction in their invention if there is different proof for the same geometry of the light guide (the drawings 4-5 is not a proof).

On Funamoto et al. (EP8878720):

Claim 10 recites “a reflective liquid crystal display device comprising (a) a display panel including two substrates spaced apart, (b) liquid crystal sandwiched between the two substrates, and (c) a reflector to reflect light through the liquid crystal”. Examiner can interpret (1) display panel including two substrates spaced apart and (2) a reflector 507 stays outside a display panel to reflect light through the liquid crystal as Figure 4 shown.

However, Funamoto et al. disclose (Fig. 10) a reflective liquid crystal display device comprising (a) a display panel 102 inherently including two substrates spaced apart, (b) liquid crystal inherently sandwiched between the two substrates, and (c) a reflector 103 (outside) to reflect light through the liquid crystal.

Applicants need to further clarify that the reflector is formed outer surface of lower substrate or is formed inner surface of lower substrate by an amendment with supported drawing.

Appellant may file another reply brief in compliance with 37 CFR 41.41 within two months of the date of mailing of this 'supplemental examiner's answer. Extensions of time under 37 CFR 1.136(a) are not applicable to this two month time period. See 37 CFR 41.43(b)-(c).

that light travels more slowly in water than in air, thus ruling out the corpuscular theory of Newton.

Attachment 1

Let light rays in an optically dense medium (glass, say) fall on a surface on the other side of which is a less optically dense medium (air, say); see Fig. 43-11. As the angle of incidence θ is increased, a situation is reached (see ray *e*) at which the refracted ray points along the surface, the angle of refraction being 90° . For angles of incidence larger than this critical angle θ_c no refracted ray exists, giving rise to a phenomenon called total internal reflection.

We find the critical angle by putting $\theta_2 = 90^\circ$ in the law of refraction (see Eq. 43-11):

$$n_1 \sin \theta_c = n_2 \sin 90^\circ,$$

or

$$\sin \theta_c = \frac{n_2}{n_1} \quad (43-13)$$

For glass and air $\sin \theta_c = (1.00/1.50) = 0.667$, which yields $\theta_c = 41.8^\circ$. Total internal reflection does not occur when light originates in the medium of lower index of refraction.

$\theta_i < \theta_c$ deflecting outwardly
Problem 2

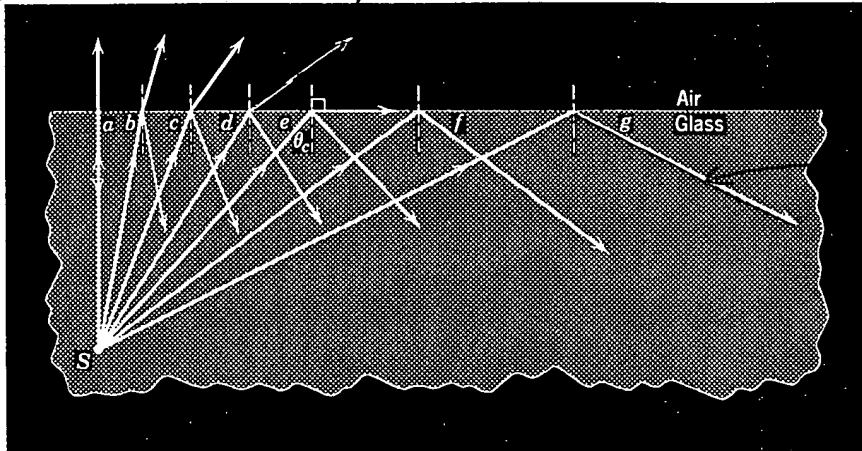

figure 43-11

$\theta_i > \theta_c$
deflecting NOT
outwardly
(see attachment 2)

Light can be "piped" from one point to another with little loss by allowing it to enter one end of a rod of transparent plastic. The light will undergo total internal reflection at the boundary of the rod and will follow its contour, emerging at its far end. Images may be transferred from one location to another, using a bundle of fine glass fibers, each fiber transmitting a small fraction of the image.*

Fiber optics techniques make possible many useful optical devices for transmitting and transforming luminous images. Figure 43-12 shows a short fiber bundle constructed so that the fibers taper in diameter along its length. The wide end is shown placed over the letter *S* in the printed word "OPTICS." We see, with the aid of a mirror placed above the bundle, that a letter *S*, reduced in size, has been transmitted by total internal reflection through the bundle to its narrow end.

* See "Fiber Optics" by N. S. Kapany, *Scientific American*, November 1960.

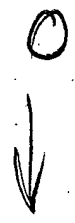

Attachment 2

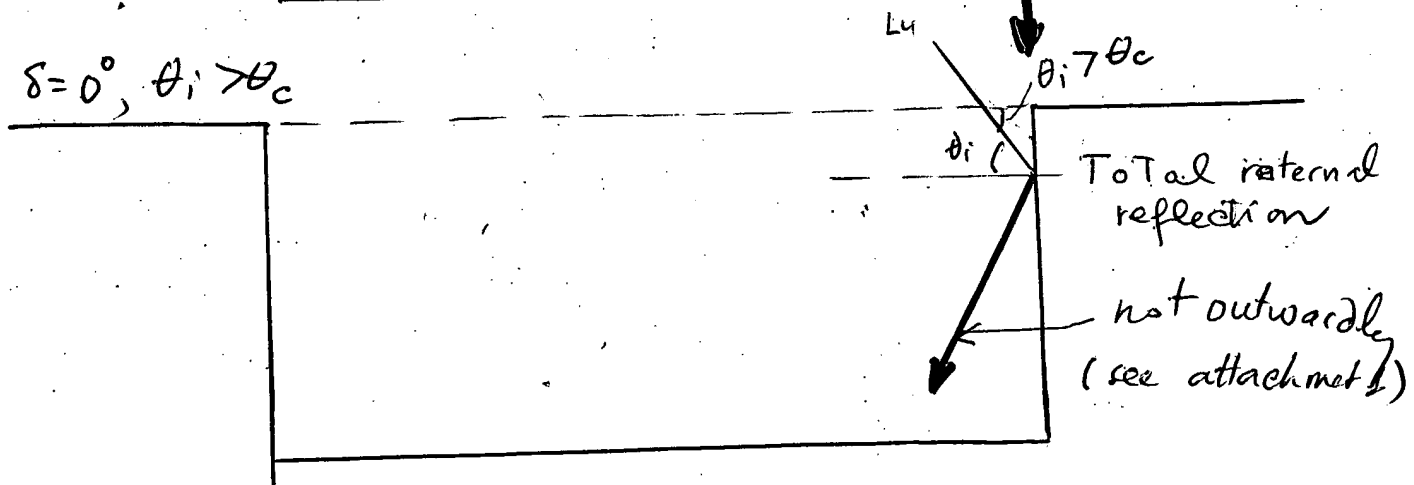
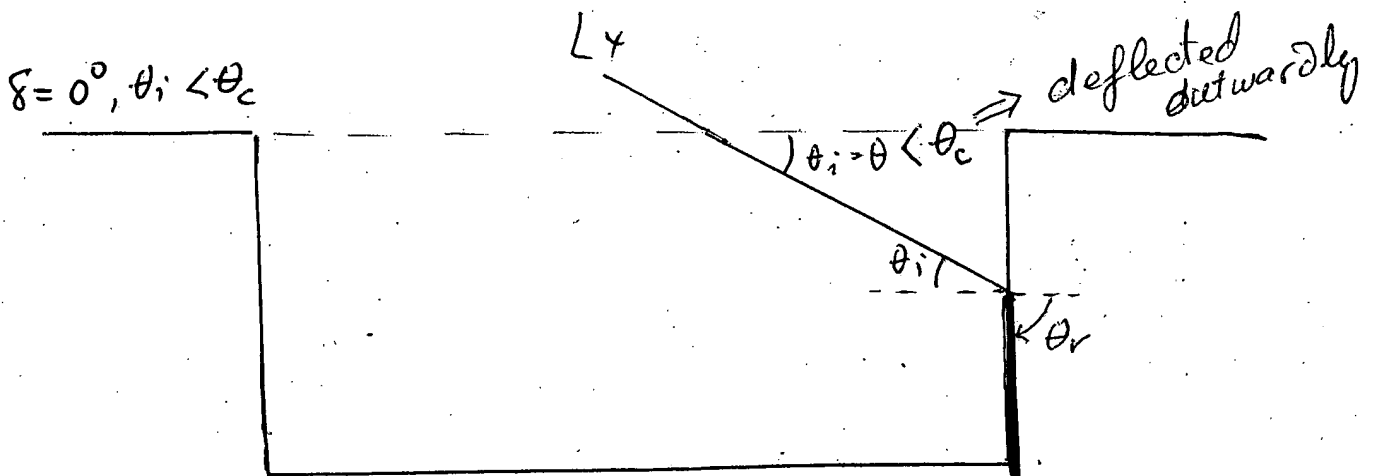
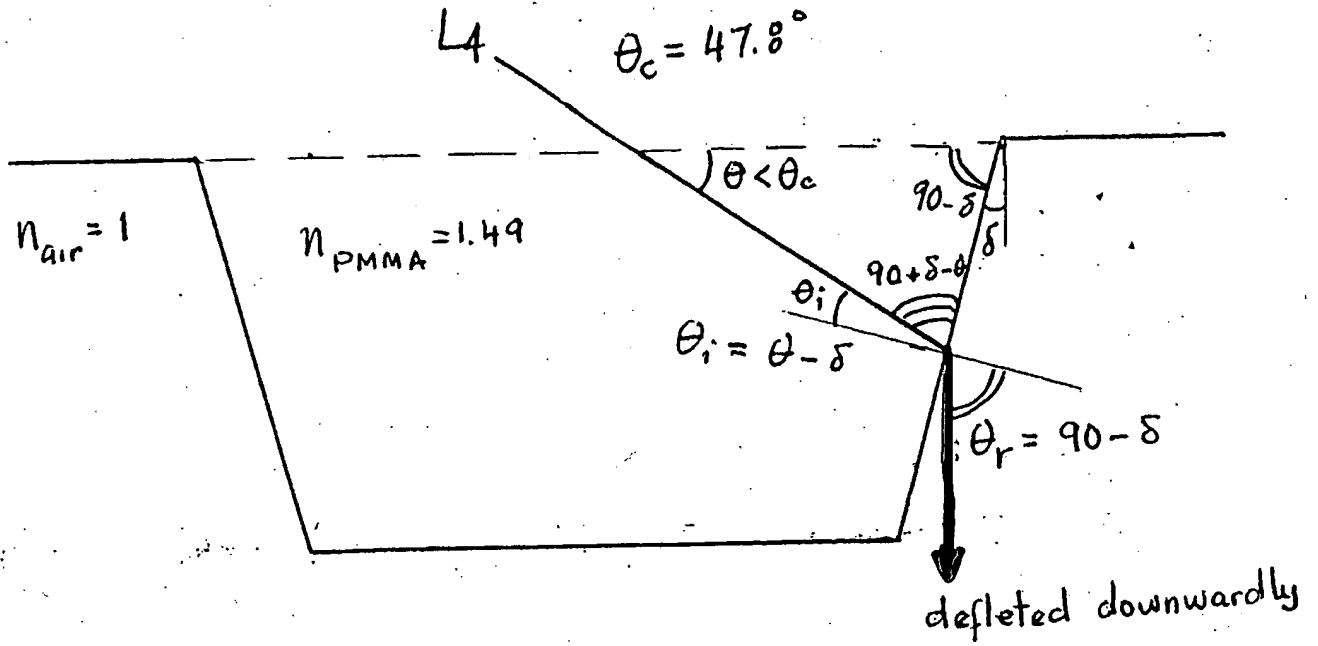

Attachment 3

FIG. 4 (Shinji et al.)

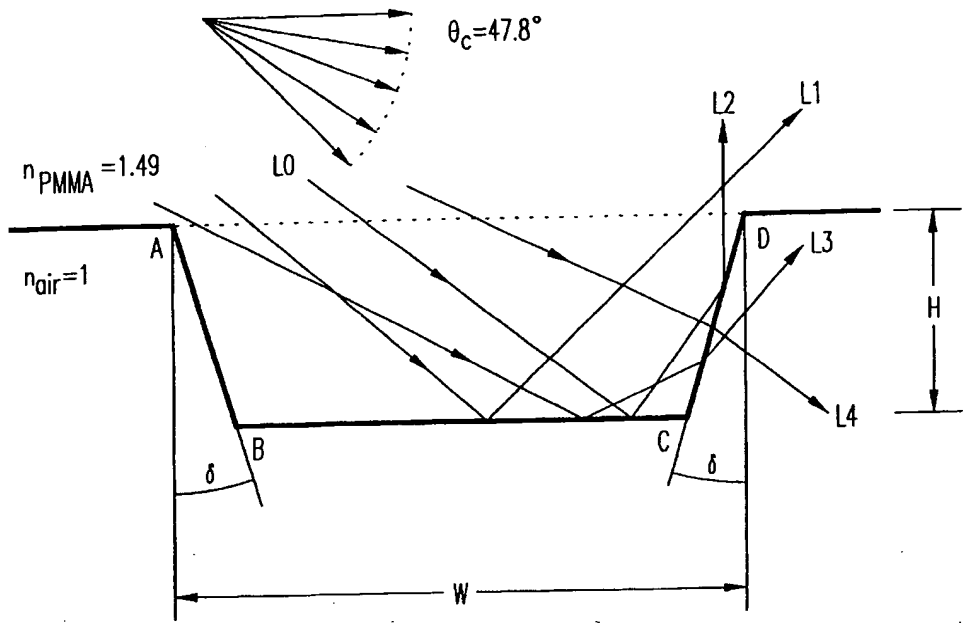

FIG. 5 (Invention)

